

BIXOLON®

User's Manual
BCD-1000 Series

Customer Display
Rev. 1.06

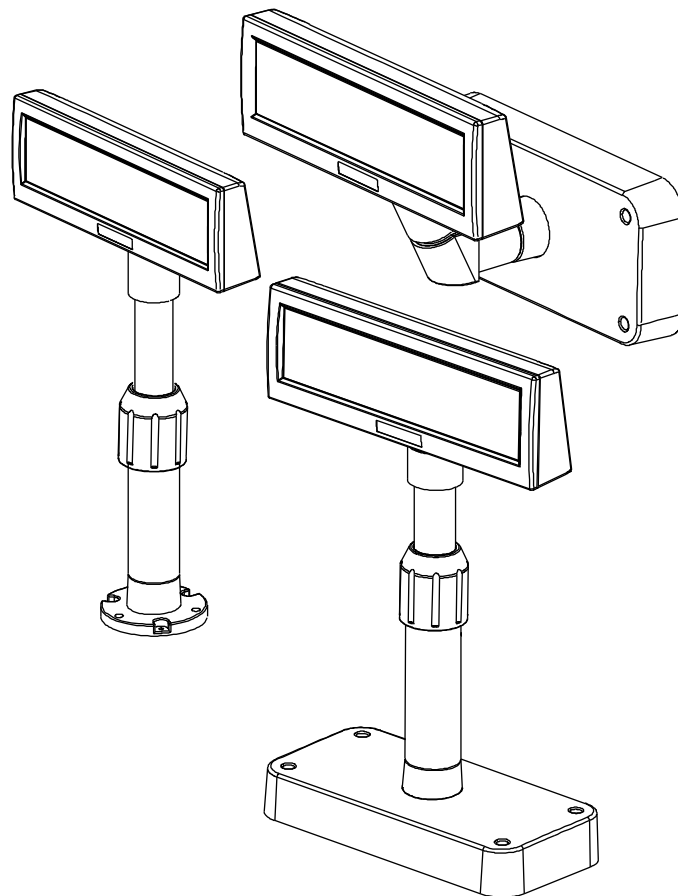

<http://www.bixolon.com>

■ Safety Precautions

In using the present appliance, please keep the following safety regulations in order to prevent any hazard or material damage.



WARNING

Violating following instructions can cause serious injury or death.

Do not plug several products in one multi-outlet.

- This can provoke over-heating and a fire.
- If the plug is wet or dirty, dry or wipe it before usage.
- If the plug does not fit perfectly with the outlet, do not plug in.
- Be sure to use only standardized multi-outlets.

PROHIBITED

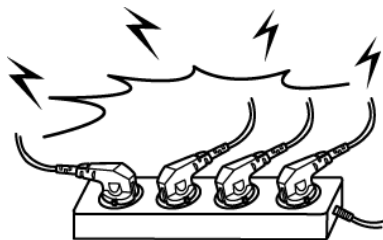

You must use only the supplied adapter.

- It is dangerous to use other adapters.

PROHIBITED



Do not pull the cable to unplug.

- This can damage the cable, which is the origin of a fire or a breakdown of the printer.

PROHIBITED

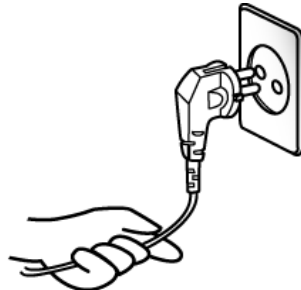

Keep the plastic bag out of children's reach.

- If not, a child may put the bag on his head.

PROHIBITED



Do not plug in or unplug with your hands wet.

- You can be electrocuted.

PROHIBITED



Do not bend the cable by force or leave it under any heavy object.

- A damaged cable can cause a fire.

PROHIBITED

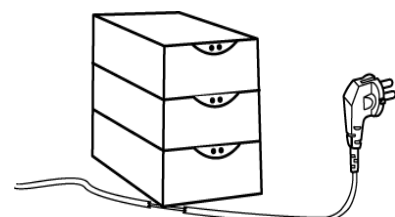



CAUTION

Violating following instructions can cause slight wound or damage the appliance.

If you observe a strange smoke, odor or noise from the Display, unplug it before taking following measures.

- Switch off the Display and unplug the set from the mains.
- After the disappearance of the smoke, call your dealer to repair it.

TO UNPLUG

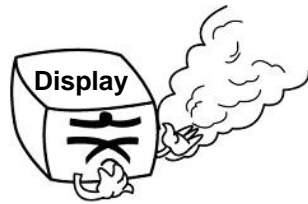

Keep the desiccant out of children's reach.

- If not, they may eat it.

PROHIBITED



Install the printer on the stable surface.

- If the Display falls down, it can be broken and you can hurt yourself.

PROHIBITED

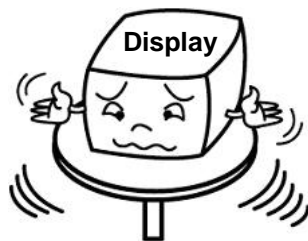

Use only approved accessories and do not try to disassemble, repair or remodel it for yourself.

- Call your dealer when you need these services.

DISASSEMBLING PROHIBITED

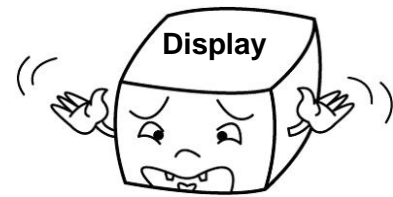

Do not let water or other foreign objects in the Display.

- If this happened, switch off and unplug the Display before calling your dealer.

PROHIBITED

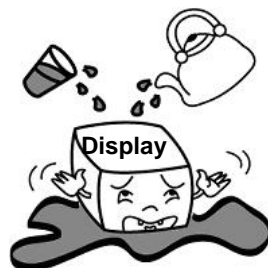

■ Table of Contents

1. Complete Product Configuration	5
2. Unpacking	7
2-1 BCD-1000D Type	7
2-2 BCD-1000DN Type.....	7
2-3 BCD-1000W Type.....	8
2-4 BCD-1000WN Type	8
3. Defaults & Options by Product Type	9
3-1 Serial Type	9
3-1-1 Direct Type : Direct connection with the VFD, bypassing the Board	9
3-1-2 Pass through Type.....	10
4. Connection Type & Size	11
4-1 BCD-1000D Type	11
4-2 Size.....	12
4-2-1 Desk Top Type	12
4-2-2 Wall Mount Type	12
4-2-3 Etc.	12
5. Function	13
5-1 Rotation	13
5-2 Angling.....	14
6. Connection	15
6-1 Direct Type Pin Connection	15
6-1-1 Interface Specification	15
6-1-2 Connector Signal Assignments.....	16
6-1-3 Installation Instructions	17
6-1-4 Signal Assignments (Cable-end DSUB).....	17
6-1-5 DC Power Jack.....	17
6-2 Serial pin Connection.....	18
6-2-1 Host interface connector.....	18
6-2-2 Host interface connector signal assignments	18
6-2-3 Printer interface connector.....	19
6-2-4 Printer interface connector signal assignments	19
7. Switches	20
7-1 Display Switch	20
7-2 DIP switches.....	20
7-3 Memory Switches	21
8. Power Control	22
8-1 Serial Board.....	23
8-1-1 Jumper1.....	23
8-1-2 Jumper2.....	23

9. Appendix 24
9-1 Specifications..... 24
9-2 Certification..... 24
9-3 Label Types 25

1. Complete Product Configuration

The display types offered include the following :

- Desk-Top Type (BCD-1000D)
- Desk-Top Fix Type (BCD-1000DN),
- Wall Mount Types (BCD-1000W/WN)..

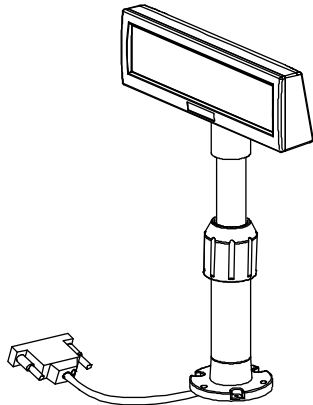

BCD-1000DN

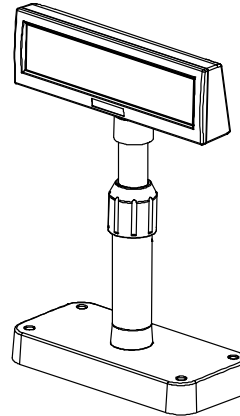

BCD-1000D

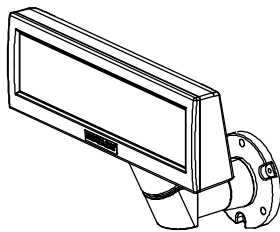

BCD-1000WN

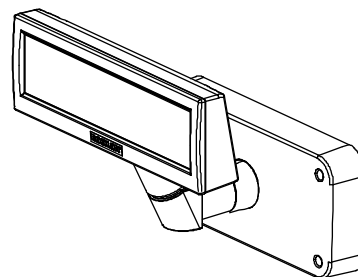

BCD-1000W

※ NOTES

For the wall-mounting and table installation, please use an electric screwdriver.

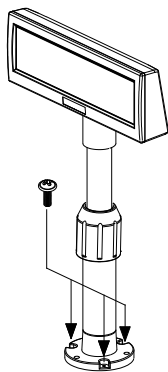

BCD-1000DN / WN

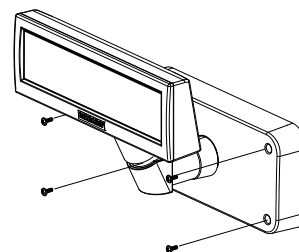

BCD-1000D / W

2. Unpacking

2-1 BCD-1000D Type

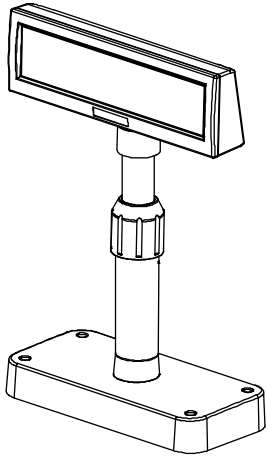

Display Set



Manual



Install CD

2-2 BCD-1000DN Type

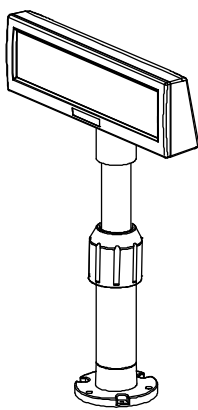

Display Set



Manual



Install CD

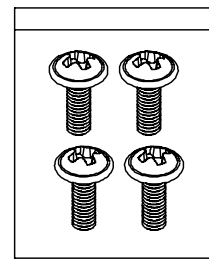

Screw
(M3*10) Tapping

2-3 BCD-1000W Type

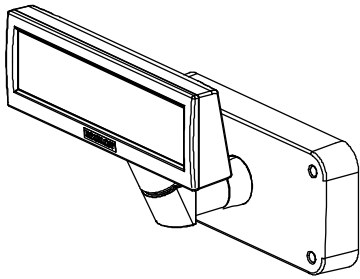

Display Set



Manual



Install CD

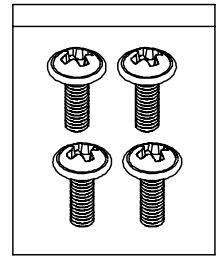

Screw
(M3*10) Tapping

2-4 BCD-1000WN Type

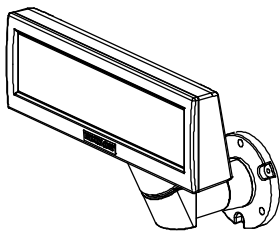

Display Set

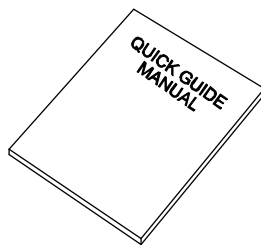

Manual



Install CD

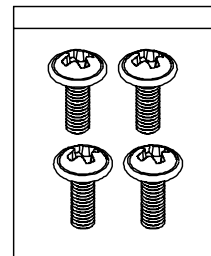

Screw
(M3*10) Tapping

3. Defaults & Options by Product Type

3-1 Serial Type

3-1-1 Direct Type : Direct connection with the VFD, bypassing the Board

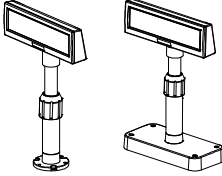
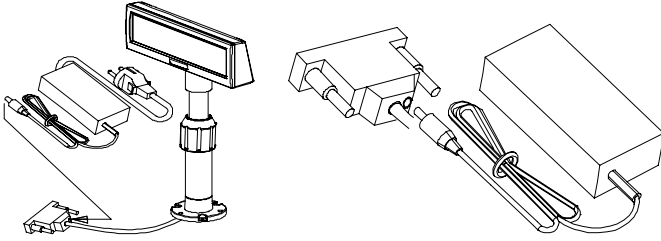
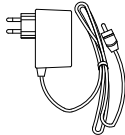
Item	VFD- Serial	Etc
Set Default		
Connection	<p data-bbox="544 913 1193 987">Connection of Serial Jack via separate SMPS Usage Voltage: 5~24V(2pin)</p> 	
Power Default	 <p data-bbox="691 1644 1043 1675">12V (K410-00004C,D,E,F,H,I)</p>	





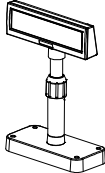
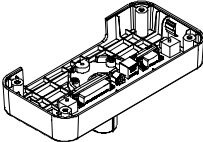
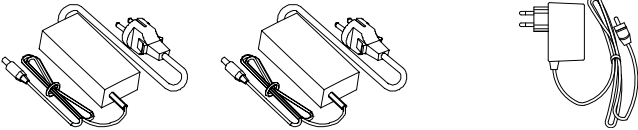
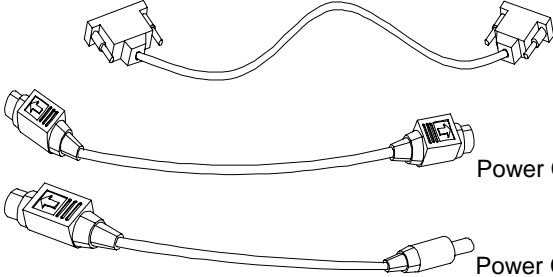



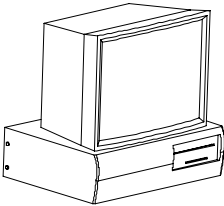
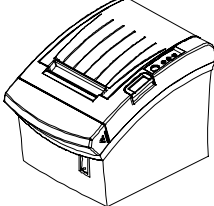
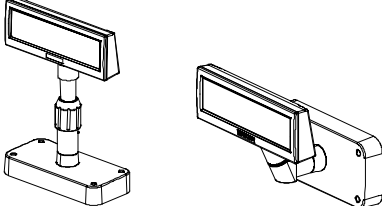

3-1-2 Pass through Type

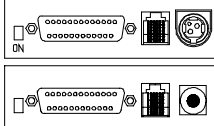
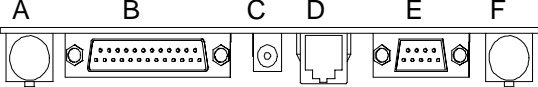
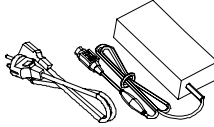
Host (PC) → VFD → Printer

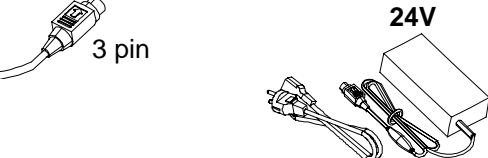
Item	VFD- Serial	Etc
Set Default		
Board Default		
Power Option	 <p data-bbox="525 1173 692 1234">24V, 2.5A : K404-00007A</p> <p data-bbox="756 1173 924 1234">24V, 1.5A : K402-00008B</p> <p data-bbox="975 1173 1254 1234">12V, 1.25A: K410-00004C,D,E,F,H,I</p>	
Cable Option	 <p data-bbox="963 1451 1246 1480">9PM.25PF (K604-00086A)</p> <p data-bbox="884 1547 1326 1576">Power Cable 3P/3P 1.8M (K610-00005B)</p> <p data-bbox="884 1644 1326 1673">Power Cable 3P/2P 1.8M (K610-00005G)</p>	

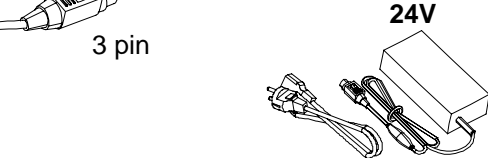
4. Connection Type & Size

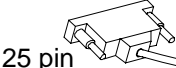
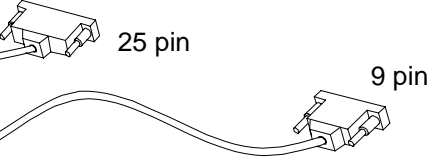
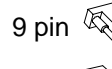
4-1 BCD-1000D Type

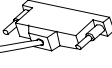
Basic Units			
Interface			
Power Connection Method 1 VFD Separate Power Supply			
Power Connection Method 2 SMPS→VFD →Printer			
Power Connection Method 3 SMPS→VFD →Printer			
Cable Connection Method 1 Host→VFD →Printer			
Cable Connection Method 2	 		
Etc	<p>A: Power Supply Connector (Out DC 24V, 3pin) B: Host Interface Connector (D-SUB 25pin, Female) C: Power Supply Connector (In DC 5~24V, 2pin) D: Display Unit Connector E: Printer Interface Connector (D-SUB 9pin, Male) F: Power Supply Connector (In DC 24V, 3pin)</p>		

4-2 Size

4-2-1 Desk Top Type

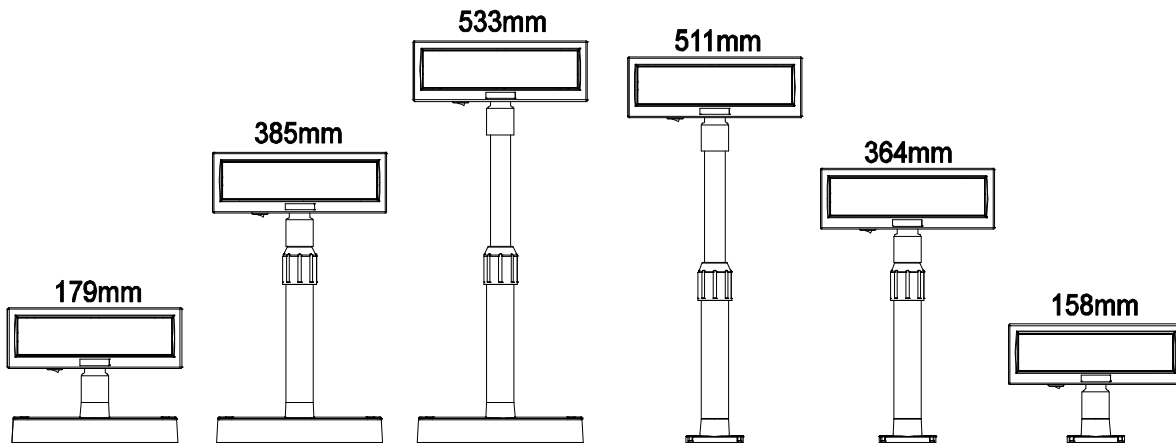

4-2-2 Wall Mount Type

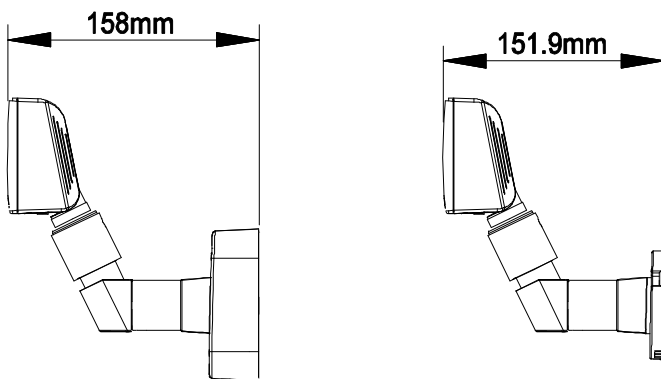

4-2-3 Etc.

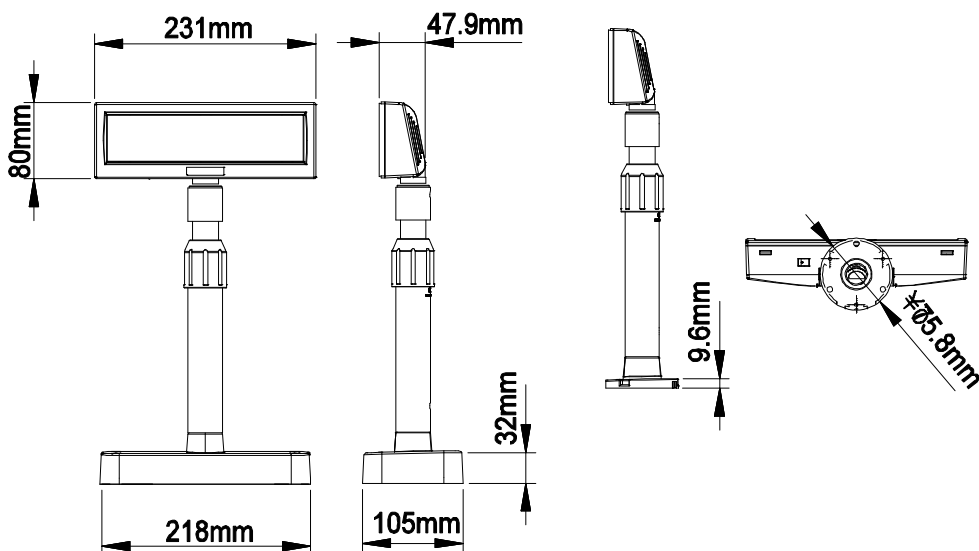

5. Function

5-1 Rotation

This product allows display rotation to any position or angle desired by the user. Please adhere to the following instructions during installation to prevent possible product damage and/or malfunction.

Following assembly, follow the sequence below to fix the DISPLAY in the desired position.

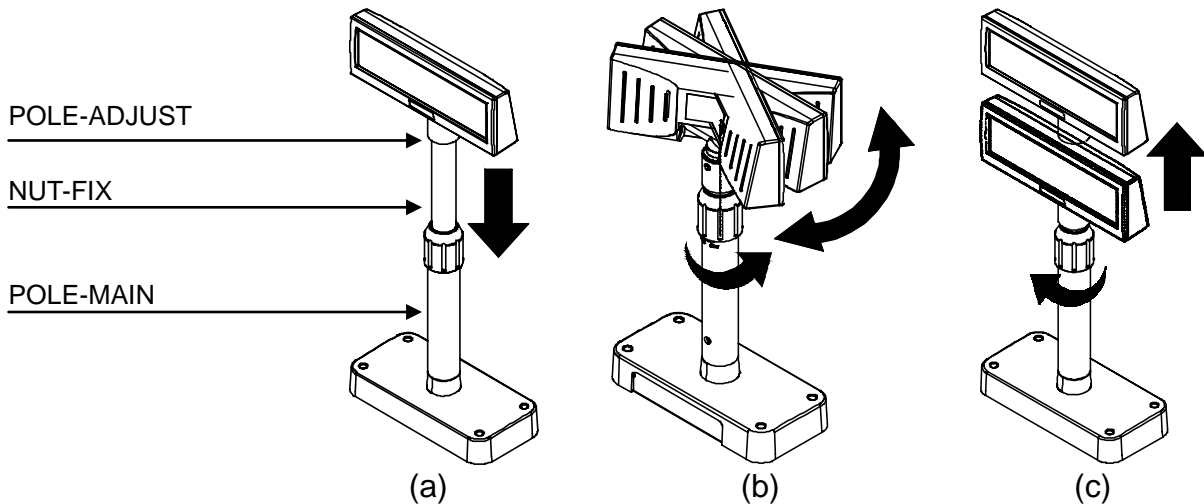

(a) Lower the DISPLAY UNIT in the direction of the arrow. Rotate the NUT-FIX to allow for lowering. (Please refer to the product OPEN/CLOSE label.)

(b) Rotate the DISPLAY UNIT to the desired angle.



Do not rotate the DISPLAY UNIT in any direction for more than one full revolution. (Beware as the DISPLAY UNIT can be rotated continuously.)

(c) After setting the DISPLAY to the desired position, secure the NUT-FIX. (When raising the DISPLAY UNIT, lateral movement is prevented.) Make sure to tighten the NUT-FIX after raising the DISPLAY UNIT to the desired height.



As excessive tightening of the NUT-FIX can result in product damage and/or malfunction, secure only to the extent that the DISPLAY UNIT is fixed and does not move.



As shown in figure (A), make sure to fully lower the DISPLAY UNIT before rotating. Rotation of the DISPLAY UNIT when it is not fully lowered will produce a clicking sound. This sound does not indicate any product breakage and is a result of the friction between the POLE-MAIN RIB and the rotation section within the POLE-ADJUST. If the DISPLAY UNIT is fully lowered, this sound will not be produced.

5-2 Angling

This product allows display tilting to any angle desired by the user. Please adhere to the following instructions during installation to prevent possible product damage and/or malfunction.

TILT ANGLE : The display can be angled left and right from the Center Line in 13° angle intervals for a total of 4 steps, 5 positions. (Angling: 52°max.)

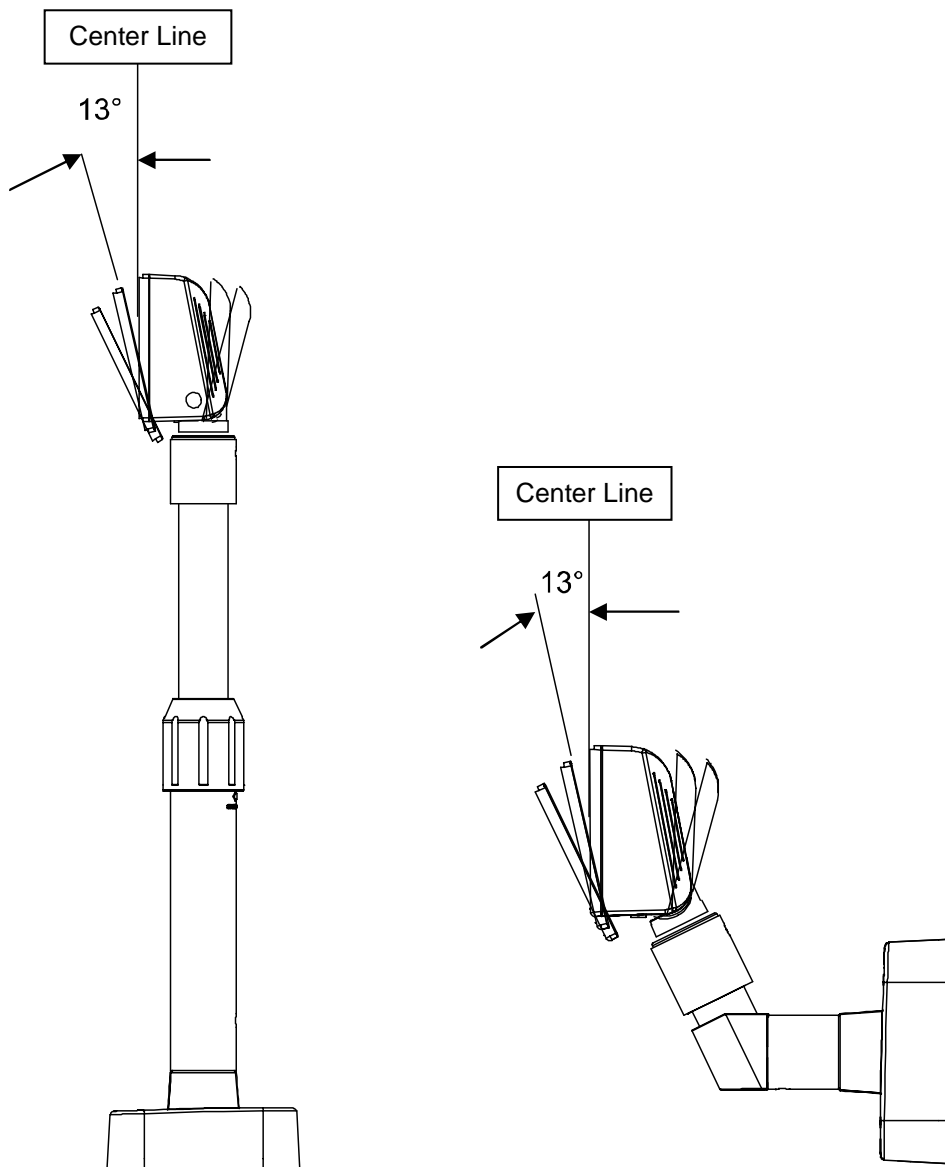

6. Connection

6-1 Direct Type Pin Connection

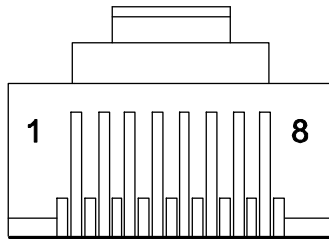

6-1-1 Interface Specification

Signal specifications	
Data transmission	Serial
Synchronization	Synchronous
Handshaking (*)	DTR/DSR control
Signal levels	MARK = -3 to -15 V logic = "1" OFF SPACE = +3 to +15 V logic = "0" ON
Baud Rate (*)	1200, 2400, 4800, 9600, 19200, 38400, 57600, 115200 bps (bps : bits per second)
Data word length (*)	7 bits, 8 bits
Parity (*)	None, odd, even
Stop bits	1 or more
(*) Selected by the DIP switches.	

6-1-2 Connector Signal Assignments

Pin NO	Signal Name	Signal Direction	Function
1	FG	-	Frame ground
2	TXD	Output	1) When the BDC-1000 is connected with the data pass through(*1) : Transmit data to the printer 2) When the BDC-1000 is connected in a stand-alone : Transmit data to the host
3	RXD	Input	Receive data from the printer
4	DSR	Input	This indicates whether the printer is ready to receive data. 1) When the BCD-1000 is connected with a data pass through(*1) : [MARK] : The printer is not ready to receive data [SPACE] : The printer is ready to receive data 2) When the BDC-1000 is connected in a stand-alone : [MARK] : The host is not ready to receive data [SPACE] : The host is ready to receive data
5	DTR	Output	This indicates whether the display is ready to receive data (*2). [SPACE] The display can receive data. [MARK] The display cannot receive data. [DTR MARK] DTR goes to MARK under the following conditions : ① The period from when the power is turned on to when the display first becomes ready to receive data. ② When the self-test is executed. ③ When the remaining space in the receive buffer becomes 40bytes or less (buffer-full state). ④ When [DSR MARK] is on, if the printer is selected by a peripheral device command. (When the BCD-1000 is connected with the data pass through.)(*1) [DTR SPACE] DTR goes to SPACE under the following conditions : ① When the display first becomes ready to receive data after power-on. ② When the self-test has ended. ③ When the remaining space in the receive buffer becomes 50bytes or more after it became 40bytes or less once.
6	SG	-	Signal GND
7	PS	-	Power supply terminal
8	PG	-	Flyback line for power supply

※ NOTES

(*1) For the data pass through and the stand alone, refer to SVC Manual connection methods for detail.

(*2) [DTR MARK] can be set by the US v command. This case differs from the above-mentioned.[DTR MARK] Refer to the US v command in section 4, Command Description.

6-1-3 Installation Instructions

STEP1. Turn the computer system power off.

STEP2. Connect the Display Cable to the RS-232 Port of the Computer.

STEP3. Connect the DC Power source by the appropriate DC Power adapter.

STEP4. Turn on the computer and the power supply unit, the display will be on and ready for receiving data.

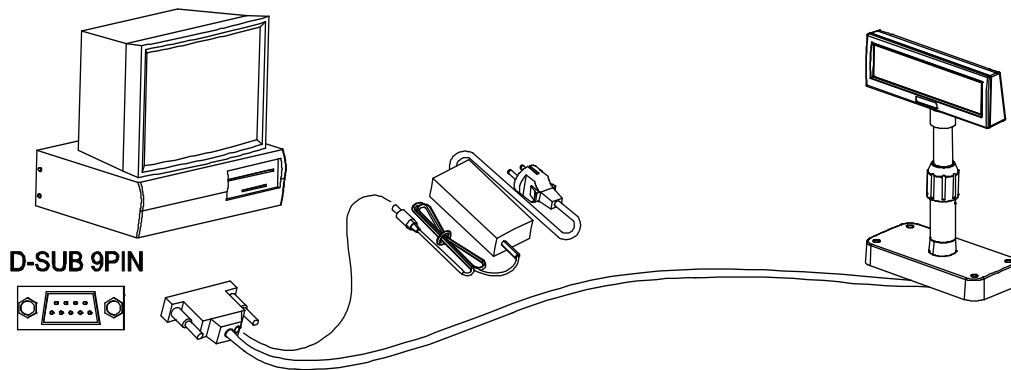

6-1-4 Signal Assignments (Cable-end DSUB)

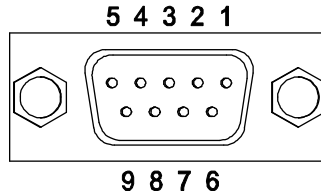

	1	2	3	4	5	6	7	8	9
pin Name	NC	RXD	TXD	DTR	GND	DSR	RTS	CTS	NC
Short Connection				●		●	●	●	

6-1-5 DC Power Jack

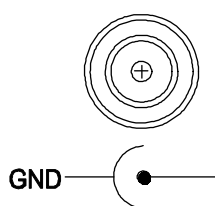

MAX 300 ~ 1350mA. +12VDC ~ +24VDC.

6-2 Serial pin Connection

6-2-1 Host interface connector

The option stand provides the host interface connector (D-SUB 25 pin Female type).

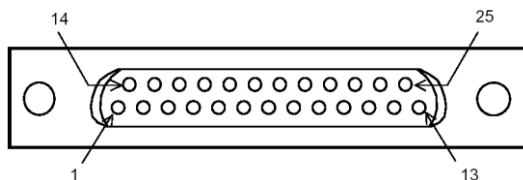

6-2-2 Host interface connector signal assignments

Pin NO	Signal Name	Signal Direction	Function
1	FG	-	Frame ground
2	TXD	Output	1) When the BDC-1000 is connected when a passthrough connection : Transmit data to the host from the printer 2) When the BDC-1000 is connected as a stand-alone : Transmit data to the host from the DM
3	RXD	Input	Receive data from the host (host → DM)
4(*1)	RTS	Output	Same as DTR
6(*2)	DSR	Input	Indicates whether the host is ready to receive data. [SPACE] The host is ready to receive data. [MARK] The host is not ready to receive data.
7	GND	-	Signal ground
20(*1)	DTR	Output	This indicates whether the display is ready to receive data. [SPACE] The display can receive data. [MARK] The display cannot receive data. [DTR MARK] DTR goes to MARK under the following conditions : ① The period from when the power is turned on to when the display first becomes ready to receive data. ② When the self-test is executed. ③ When the remaining space in the receive buffer becomes 40bytes or less (buffer-full state). ④ When [DSR MARK] is on, if the printer is selected by a peripheral device command. [DTR SPACE] DTR goes to SPACE under the following conditions : ① When the display first becomes ready to receive data after power-on. ② When the self-test has ended. ③ when the remaining space in the receive buffer becomes 50bytes or more after it became 40bytes or less once.

※ NOTES

(*1) Make sure to use either one of the RTS or the DTR terminal. Otherwise, the built-in RS-232 driver IC may be broken.

6-2-3 Printer interface connector

The option stand provides the printer interface connector (D-SUB 9 pin Male type).

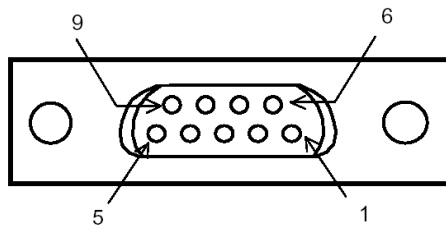
**6-2-4 Printer interface connector signal assignments**

Pin NO	Signal Name	Signal Direction	Function
2	RXD	Input	Receive data from the printer (printer → host)
3	TXD	Output	Transmit data to the printer (DM → Printer)
4	DTR	Output	Indicates whether the host is ready to receive data. [SPACE] The host is ready to receive data. [MARK] The host is not ready to receive data.
5	GND	-	Signal
6	DSR	Input	This indicates whether the display is ready to receive data from the printer. [SPACE] The printer can receive data. When the printer becomes ready to receive data the SPACE is output. [MARK] The printer cannot receive data. Even if the printer becomes ready to receive data, the MARK is not output.
9	RESET	Output	Reset signal to the printer (host → printer)

7. Switches

7-1 Display Switch

7-1-1 Feature : A Display Switch is located on the bottom of the display panel.

7-1-2 Function : Turns the power supply on/off.

7-2 DIP switches

7-2-1 Feature : Two DIP switches are located on the back of the display panel.
You can remove the DIP switch cover by pushing the hook.

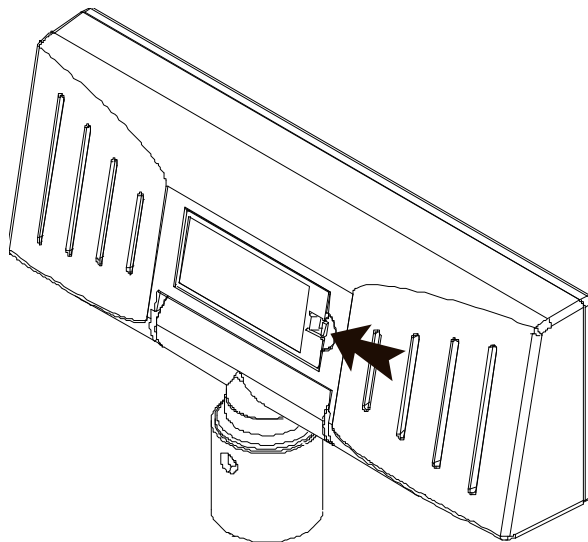

※ CAUTION

Make sure if the dip switch cover is closed prior to power on

7-2-2 Functions : The DIP switch settings are read only when the power is turned on.
Therefore, changing the settings while the power is on has no effect.

7-2-3 DIP S/W #1 Function (RS-232 Serial Input Setting)

No.	Function	Switch OFF	Switch ON		
1	Default Setting	DIP Switch Values	EEP-ROM Data Leading		
2	N.C (No Connection)	Reserved for Future Using	Reserved for Future Using		
3	Display Viewing Side	Customer Side	Operator Side		
4	Self-test Execution	Does not execute	Executes		
5~8	Command Emulation	5 6 7 8	Command Emulation	5 6 7 8	Command Emulation
		0 0 0 0	Samsung VFD	1 0 0 0	NCR Real POS
		0 0 0 1	Epson ESC/POS	1 0 0 1	PD6000
		0 0 1 0	ADM787/788	1 0 1 0	ICD2002
		0 0 1 1	DSP800	1 0 1 1	Reserved
		0 1 0 0	AEDEX	1 1 0 0	Reserved
		0 1 0 1	UTC Standard	1 1 0 1	Reserved
		0 1 1 0	UTC Enhance	1 1 1 0	Reserved
		0 1 1 1	CD5220	1 1 1 1	Reserved
		("0" : S/W OFF, "1" : S/W ON)			

7-2-4 DIP S/W #2 Function (Command Emulation Mode and Self Test Setting)

No.	Function	Switch OFF	Switch ON		
1	Data Length	8 bits	7 bits		
2	Parity using	Non parity	Parity		
3	Parity Selection	Odd	Even		
4~6	Baud-rate Selection	4 5 6	Baud-rate	4 5 6	Baud-rate
		0 0 0	9,600 bps	1 0 0	115,200 bps
		0 0 0	4,800 bps	1 0 1	57,600 bps
		0 1 1	2,400 bps	1 1 0	38,400 bps
		0 1 0	1,200 bps	1 1 1	19,200 bps
		("0" : S/W OFF, "1" : S/W ON)			
7~8	N.C (No Connection)	Reserved for Future Using	Reserved for Future Using		

7-3 Memory Switches

The following settings other than the DIP switch can be changed by software. These settings become effective after the power is turned on or initialization is executed by a command.

No.	Function	Default	Content to be set	Range to be set
Msw 10	Character code table section	n=0	Page 0 is selected	0-5, 16-19, 254, 255
Msw 11	International character set selection	n=0	U.S.A is selected	0-13
Msw 12	Brightness adjustment	n=4	100%	1-4
Msw 13	Selection of the peripheral devices	n=2	Display is selected	1-3
Msw 14	Cursor display	Selected	Selected	0, 1, 48, 49

8. Power Control

A Control board is located on the inside of the base unit. You can remove the cover PCB by pushing the hook of base unit.

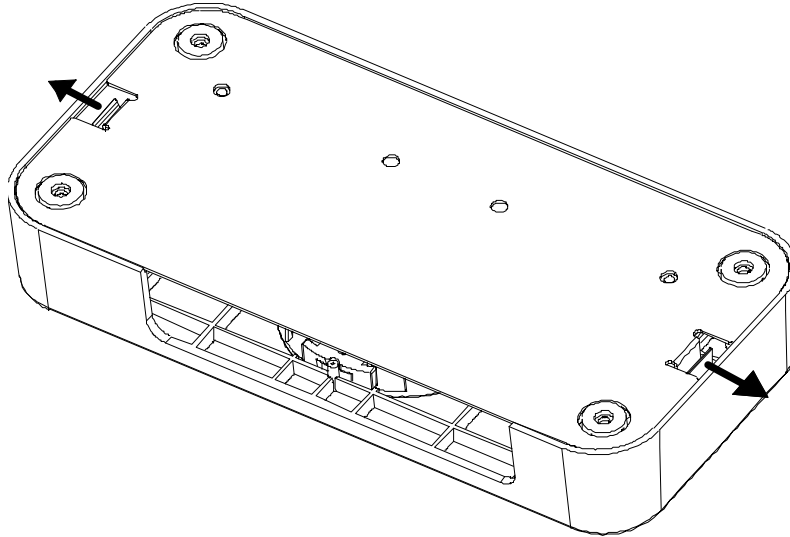



※ CAUTION

Make sure if the cover PCB is closed prior to power on

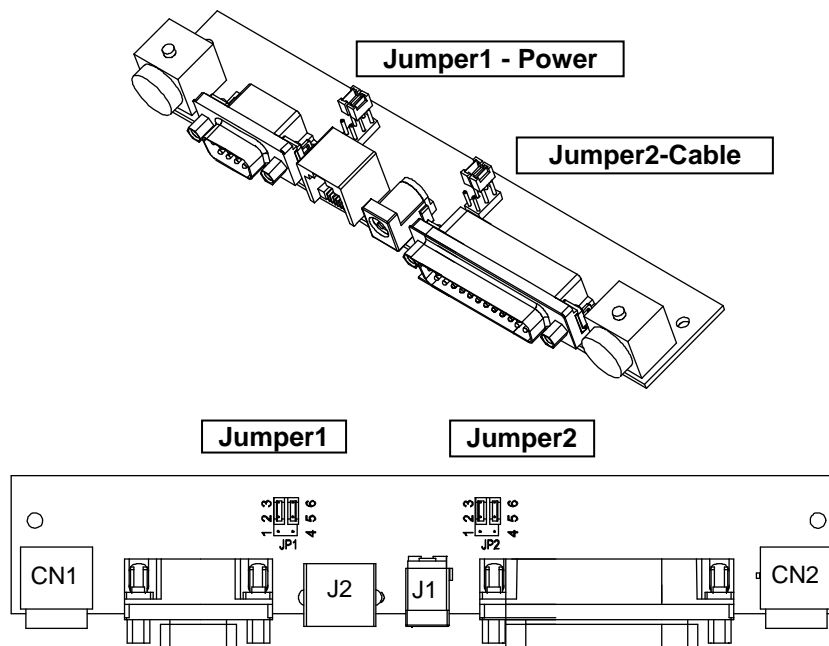
8-1 Serial Board



8-1-1 Jumper1

Connection type	JP1	Jack Type
Input Power (5~24VDC)	1-2	 Location J1
Input Power (24VDC)	2-3	 Location CN1
N/C	4-5	
Out power to print(24VDC) (Pass through Type)	5-6	 Location CN2

8-1-2 Jumper2

Some functions depend on the device's connection to the BCD-1000, such as whether a printer is connected or not with a data pass through connection, or stand alone connection.

Connection type	JP2	JP2	Function
Data pass though (default setting)	1-2	4-5	Can connect a printer which does not support the ESC = command.
Only SERIAL	2-3	5-6	No printer is connected.

9. Appendix

9-1 Specifications

Item		Description
Display	Display Method	VFD
	Brightness	800~1000 [cd/m ²]
	Character Size	5 x 7 [dot]
	Number of Columns	20 character, 2 line
	Operating Temperature	0~45 °C
	Operating Humidity	10~80 %
Reliability	VFD	20,000 [hour]

* This equipment is indooruse and all the communication hiring are limited to inside of the building.

* The switch is the disconnecting device. Turn off switch from any hazard.

9-2 Certification

1) EMC & Safety Standards

- Europe: CE EMC, TUV GS: EN60950-1: 2001
- North America: FCC Part 15 Subpart B
- Safety Standards: CB-scheme: IEC60950-1: 2001

⚠ WARNING

Use of an unprotected interface cable with this device conflicts with EMC standards. Users should only use cables approved by BIXOLON.

2) CE Mark

- EMC Directive 89/336/EEC
 - EN 55022:1994 +A1:1995 +A2:1997
 - EN 61000-3-2:2000
 - EN 61000-3-3:1995 +A1:2001
 - EN 55024:1998 +A1:2001
 - EN 61000-4-2:1995 +A1:1998 +A2:2001
 - EN 61000-4-3:1996 +A1:1998 +A2:2001
 - EN 61000-4-4:2004
 - EN 61000-4-5:1995 +A1:2001
 - EN 61000-4-6:1996 +A1:2001
 - EN 61000-4-11:1994 +A1:2001
- Low Voltage Directive 73/23/EEC
 - Safety: EN60950-1:2001

3) WEEE (Waste Electrical and Electric Equipment)



This marking shown on the product or its literature, indicates that it should not be disposed with other household wastes at the end of its working life. To prevent possible harm to the environment or human health from uncontrolled waste disposal, please separate this from other types of wastes and recycle it responsibly to promote the sustainable reuse of material resources.

Household users should contact either the retailer where they purchased this product, or their local government office, for details of where and how they can take this item for environmentally safe recycling. Business users should contact their supplier and check the terms and conditions of the purchase contract. This product should not be mixed with other commercial wastes for disposal.

4) Rating Label Symbol Information



■ ■ ■ DC (Direct current)

9-3 Label Types

The label types used with this printer is as follows.

- BIXOLON Logo Labels: PET
- Rating Labels: PP
- Other Labels: PET